

24hours Time Switch with Backup Battery

BH-TS20R

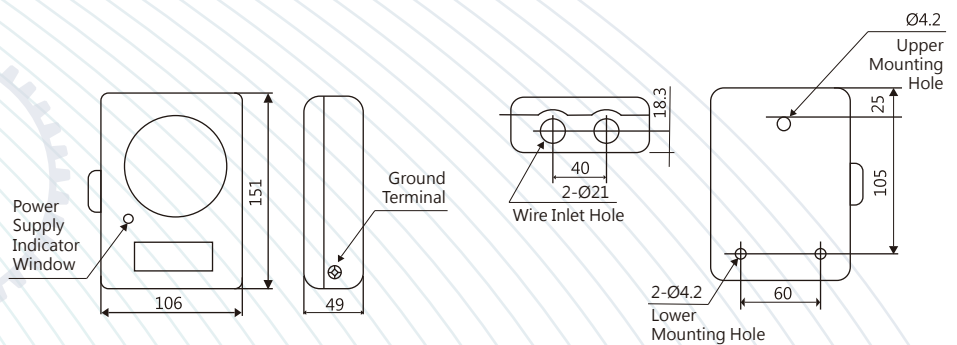

Standard	EN 60730-2-7:2010 , EN 60730-1:2011
Rated Voltage	100-240VAC
Frequency	50/60Hz
Power Consumption	110V / 1W, 220V 2W
Driving Method	Quartz Controlled Stepping Motor
Working Reserve Time	150Hours
Resistive Load	20A
Incandescent Lamp	10A
Motor	110V 750W, 220V 1500W
Minimun Unit / Interval	15 Minutes / 15 Minutes
Ambient Temperature	-10°C~+50°C
Ambient Humidity	Max.85%
Dimension	151mm(H) x 106mm(W) x 49mm(D)



BH-TS30R



Standard	EN 60730-2-7:2010 , EN 60730-1:2011
Rated Voltage	100-240VAC
Frequency	50/60Hz
Power Consumption	110V / 1W, 220V 2W
Driving Method	Quartz Controlled Stepping Motor
Working Reserve Time	100Hours
Resistive Load	30A
Incandescent Lamp	25A
Motor	110V 1500W, 220V 3000W
Minimun Unit / Interval	15 Minutes / 30 Minutes
Ambient Temperature	-10°C~+50°C
Ambient Humidity	Max.85%
Dimension	188mm(H) x 131mm(W) x 57mm(D)

